

PRODUCT DETAILS

BIANCO NXT BLC series are horizontal, single stage, stainless steel centrifugal pumps, suitable for domestic and industrial applications.

Their premium quality stainless steel construction and nitrile elastomers allows for the pumping of clean or moderately aggressive fluids for temperatures up to 85 deg C

APPLICATIONS

- Pumping clean or moderately aggressive fluids
- Water supply
- Water transfer
- Water circulation
- Tank Emptying
- Pressure boosting
- Washing cars
- Gardening
- Irrigation
- Fountains
- Dairy services
- Vat wash

FEATURES

- Compact, simple design
- Close coupled 240V single phase TEFC motor with in-built auto reset thermal overload
- Quiet and reliable
- Floating nose sealing ring for higher efficiency
- Corrosion resistant 304 stainless steel pump body, impeller, diffuser, seal support and pump shaft. Nitrile o-rings



TECHNICAL DATA

RATED POWER (W)	0.75kW
MAX. FLOW [LPM]	300 l/min
MAX. HEAD [M]	20m
MAX OPERATING PRESSURE	8 bar
MOTOR INSULATION	F Class
MOTOR PROTECTION	In-built thermal overload
MAX AMBIANT TEMP	40 deg C
MAX LIQUID TEMPERATURE	3 - 85 deg C

RATED VOLTAGE	415v (-6%, +10%) 3 PH 50 Hz
RATED CURRENT	1.8 amps
PROTECTION CLASS	IP44
MECHANICAL SEAL	Graphite/Ceramic/Nitrile
INLET	1 1/2" BSPF
OUTLET	1 1/4" BSPF
CARTON DIMENSIONS	410 x 240 x 270mm
GROSS WEIGHT (KG)	14.0 kg

CURVE

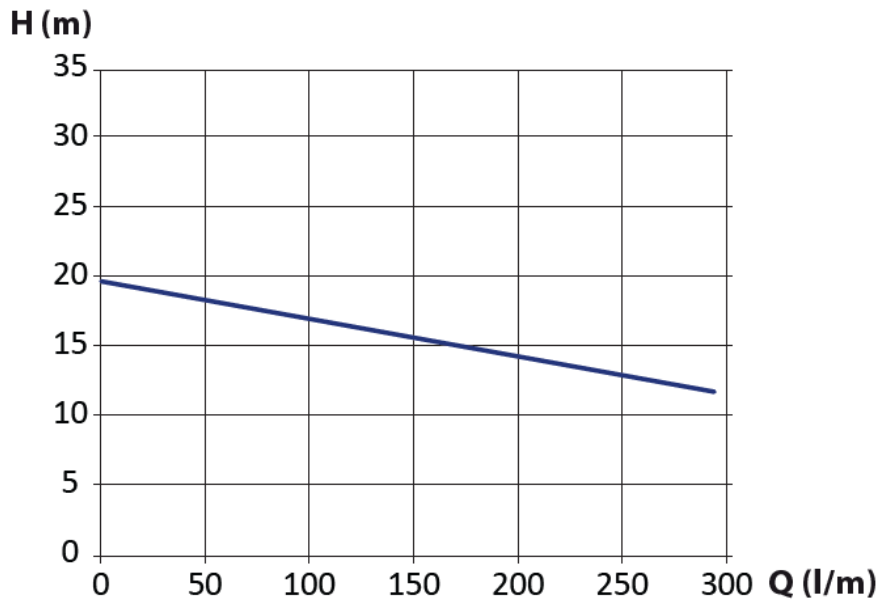

DIMENSIONS

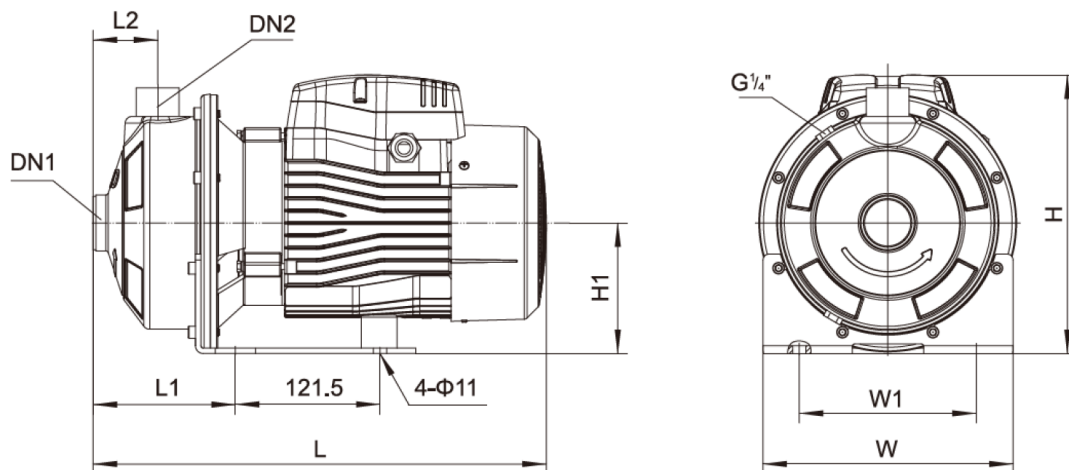

Model	DN1 (BSPF)	DN2 (BSPF)	L (mm)	W (mm)	H (mm)	L1 (mm)	L2 (mm)	W1 (mm)	H1 (mm)
BIA-BLC210-75S2T	1-1/2"	1-1/4"	392	210	234	119	55	149	110

WARRANTY / CERTIFICATIONS

